



Racing
ANDERSON

1/5 EP MOTORACE



ASSEMBLY INSTRUCTION
NOTICE DE MONTAGE
INSTRUCCIONES PARA EL MONTAJE

PAT. P.

Required For Operation

★Radio Control Set-2Channel

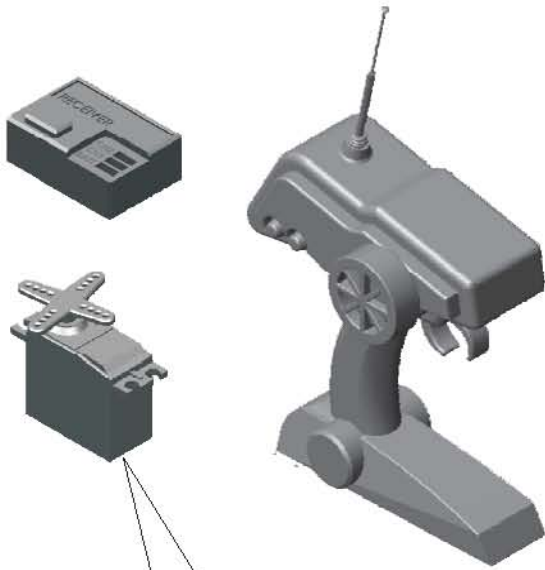

★AA-Size Batteries 8Pcs. for Transmitter



★Electronic Speed Control

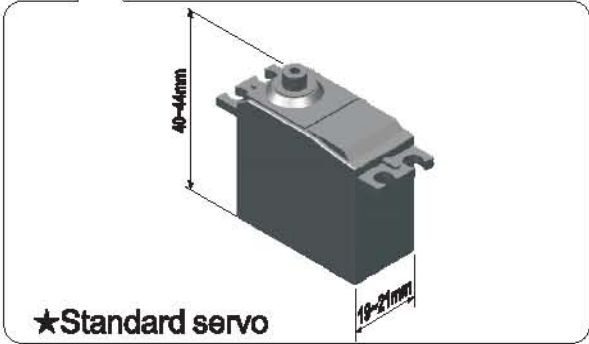
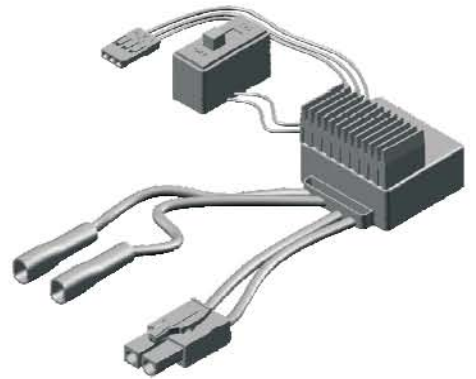

★7.2V NI-MH Battery Pack



Tools Required

★Instant Glue



★OIL / Grease



★Long Nose Pliers



★Modelling Knife



★Scissors



★Small Scissors



★3.0mm Allen Wrench



★2.5mm Allen Wrench



★2mm Allen Wrench



★1.5mm Allen Wrench



★7mm Nut Driver



★5.5mm Nut Driver



★Phillips Screwdriver (L,M,S)



01

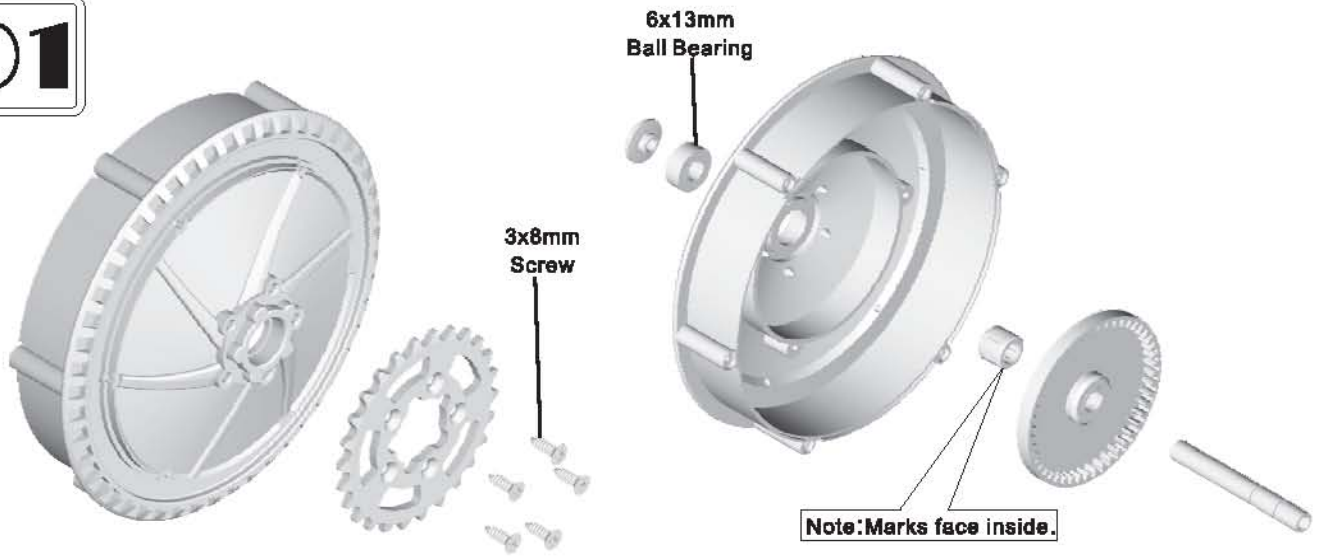

02



03



04

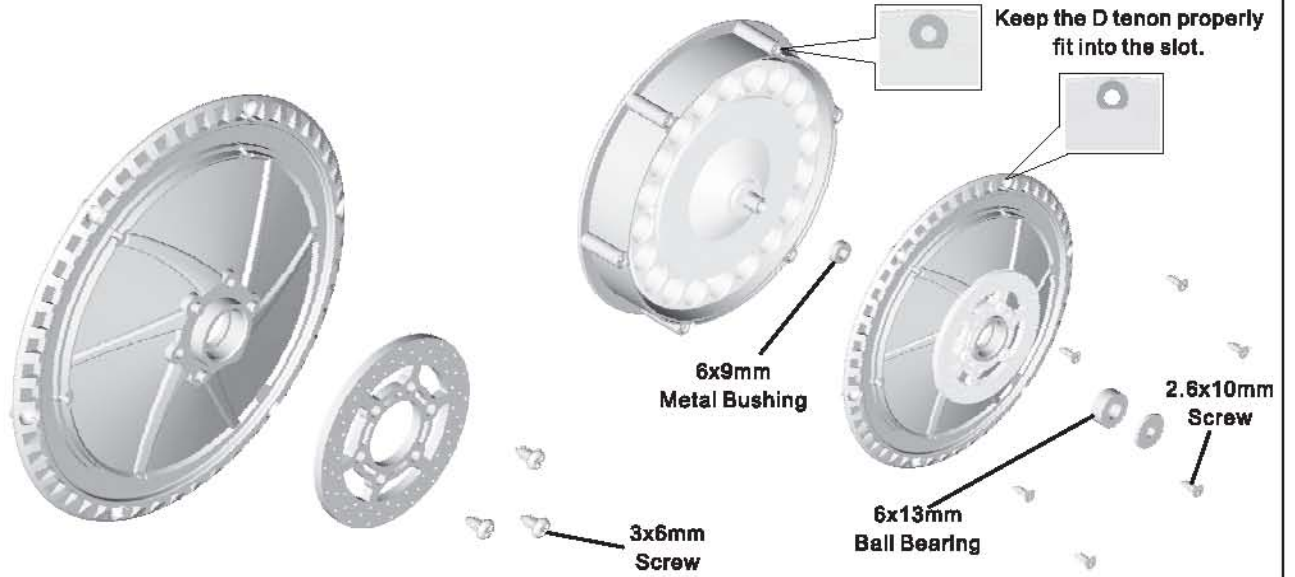

05



06

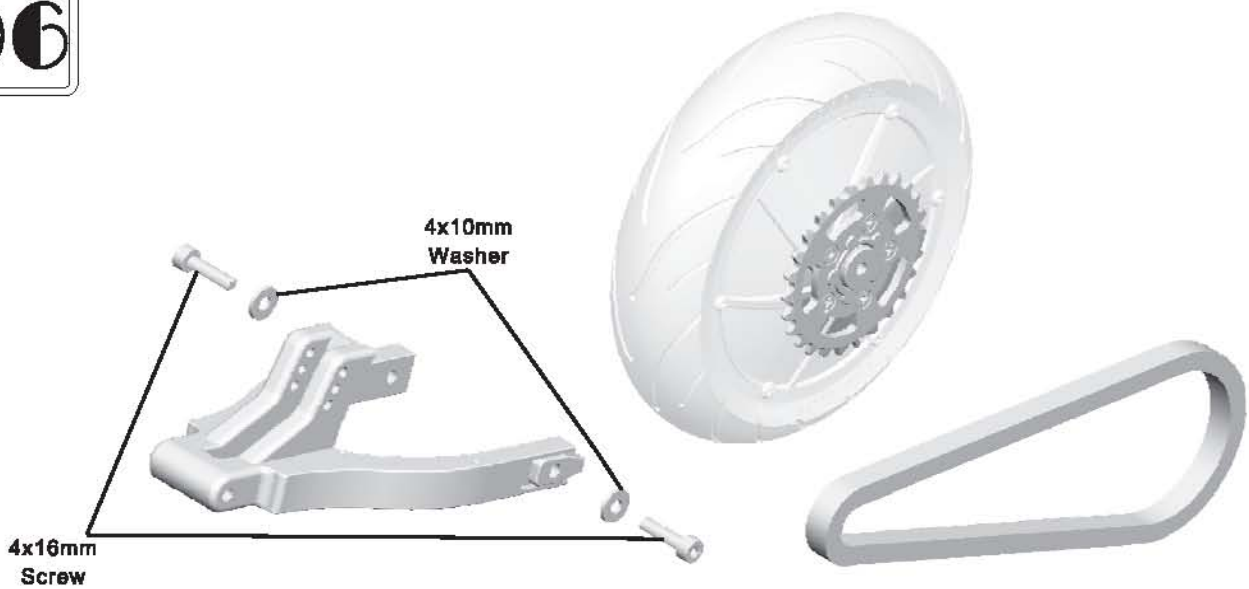

07



08

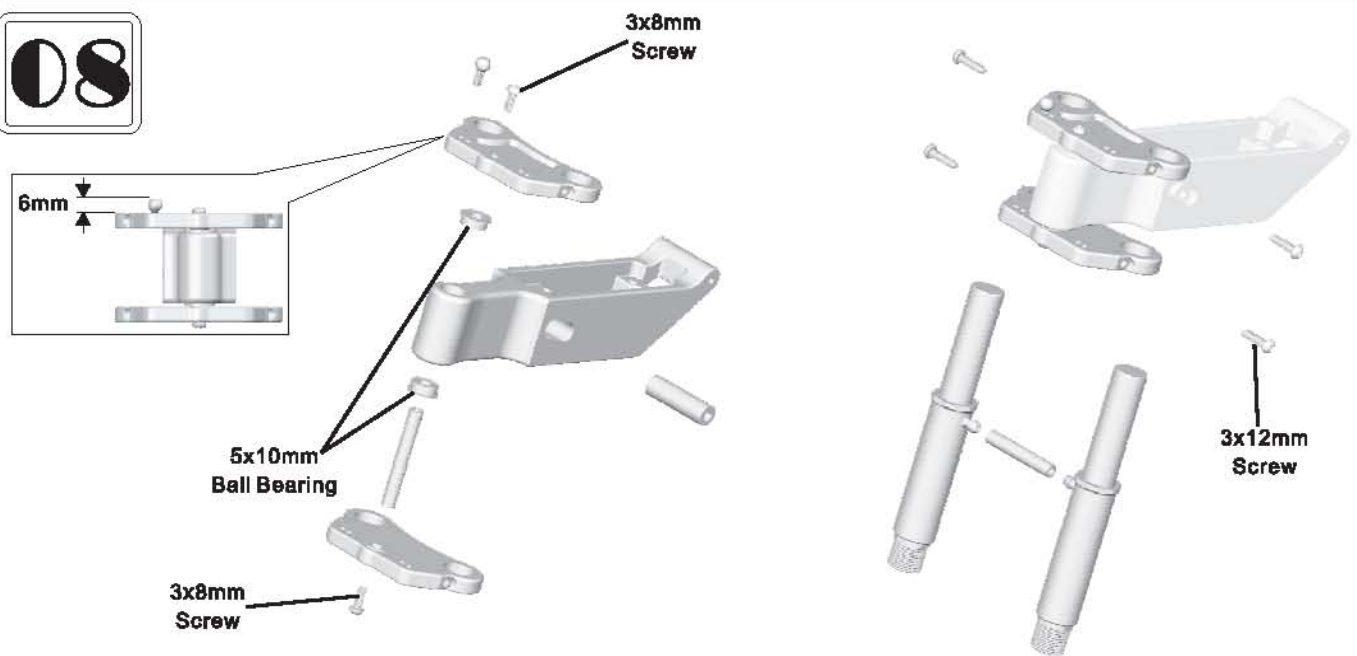

09

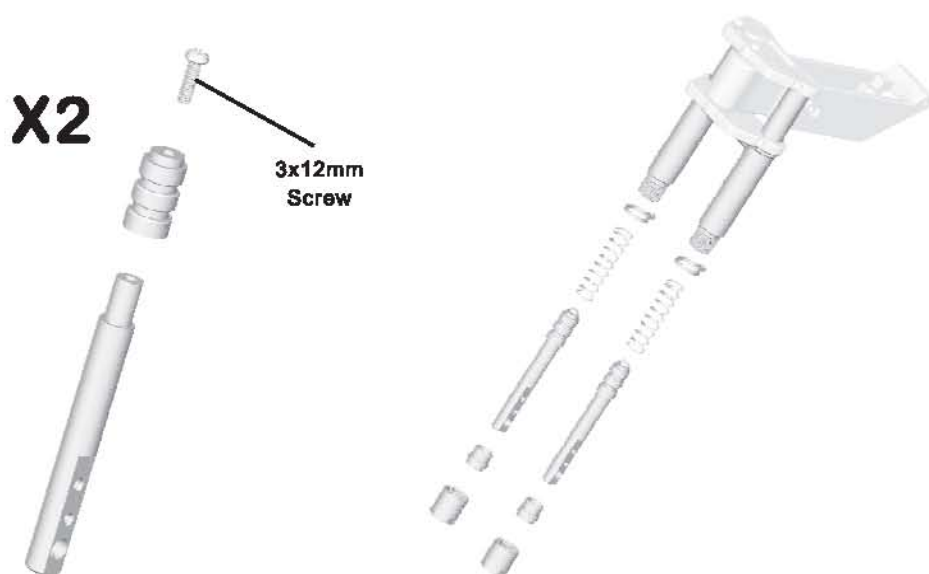

10

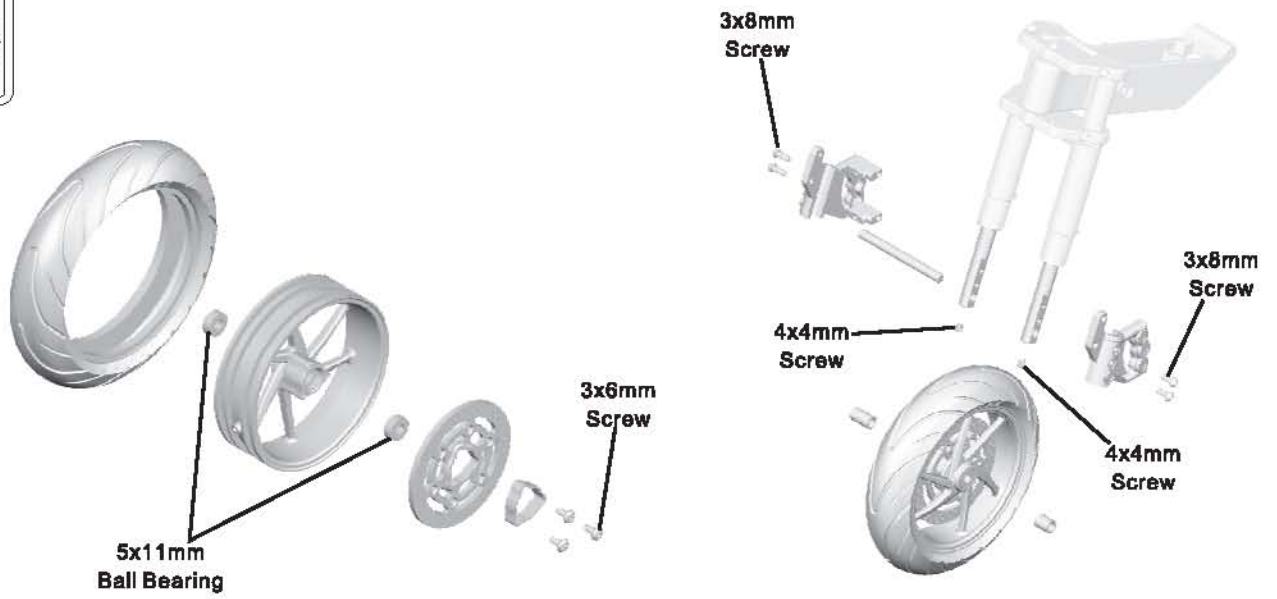

11



12



13



14



15

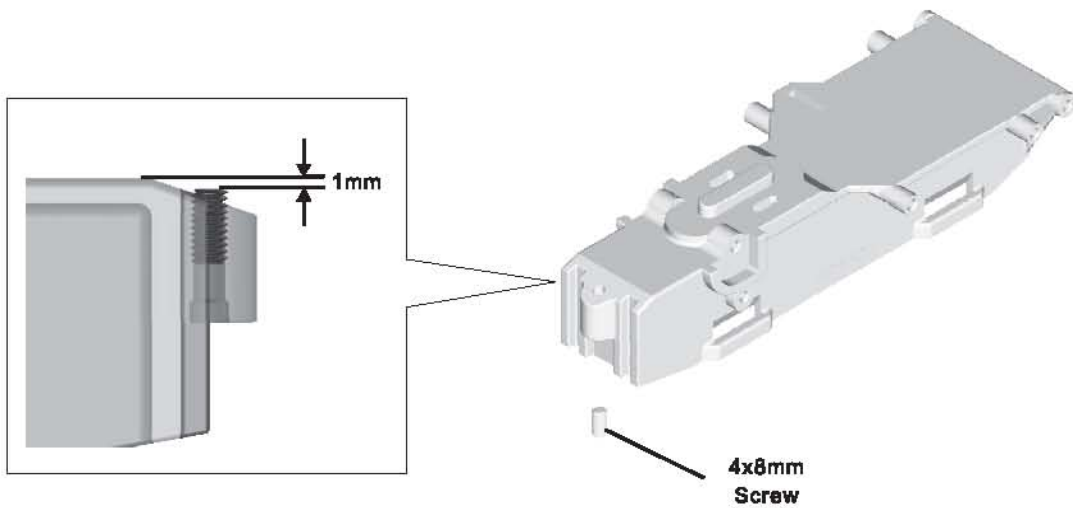

16

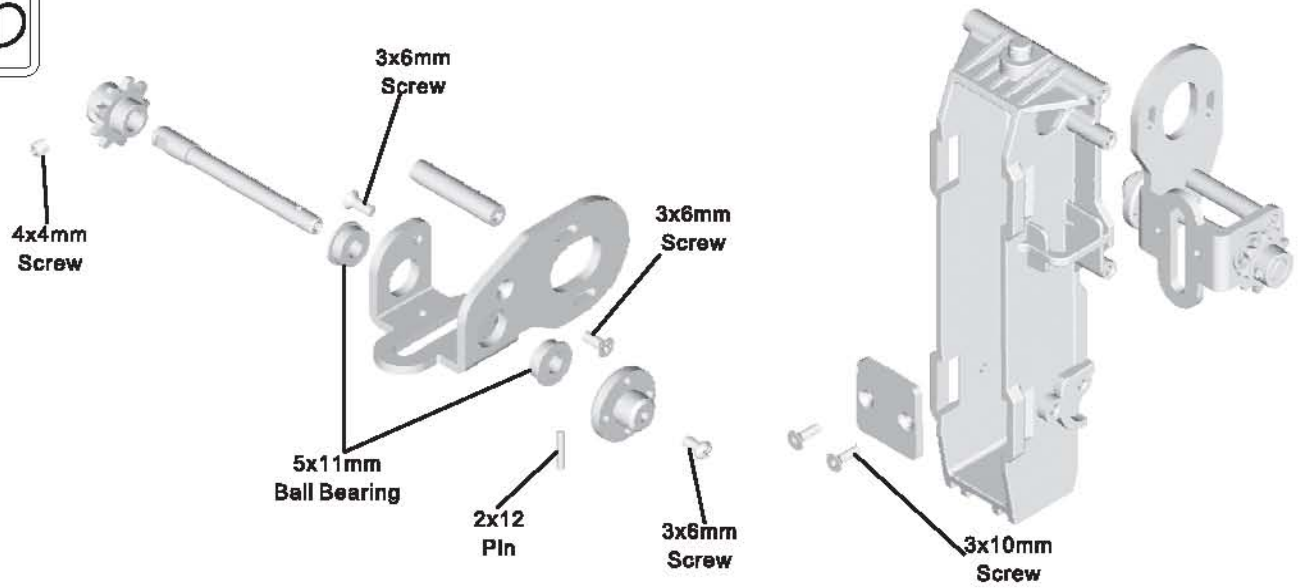

17

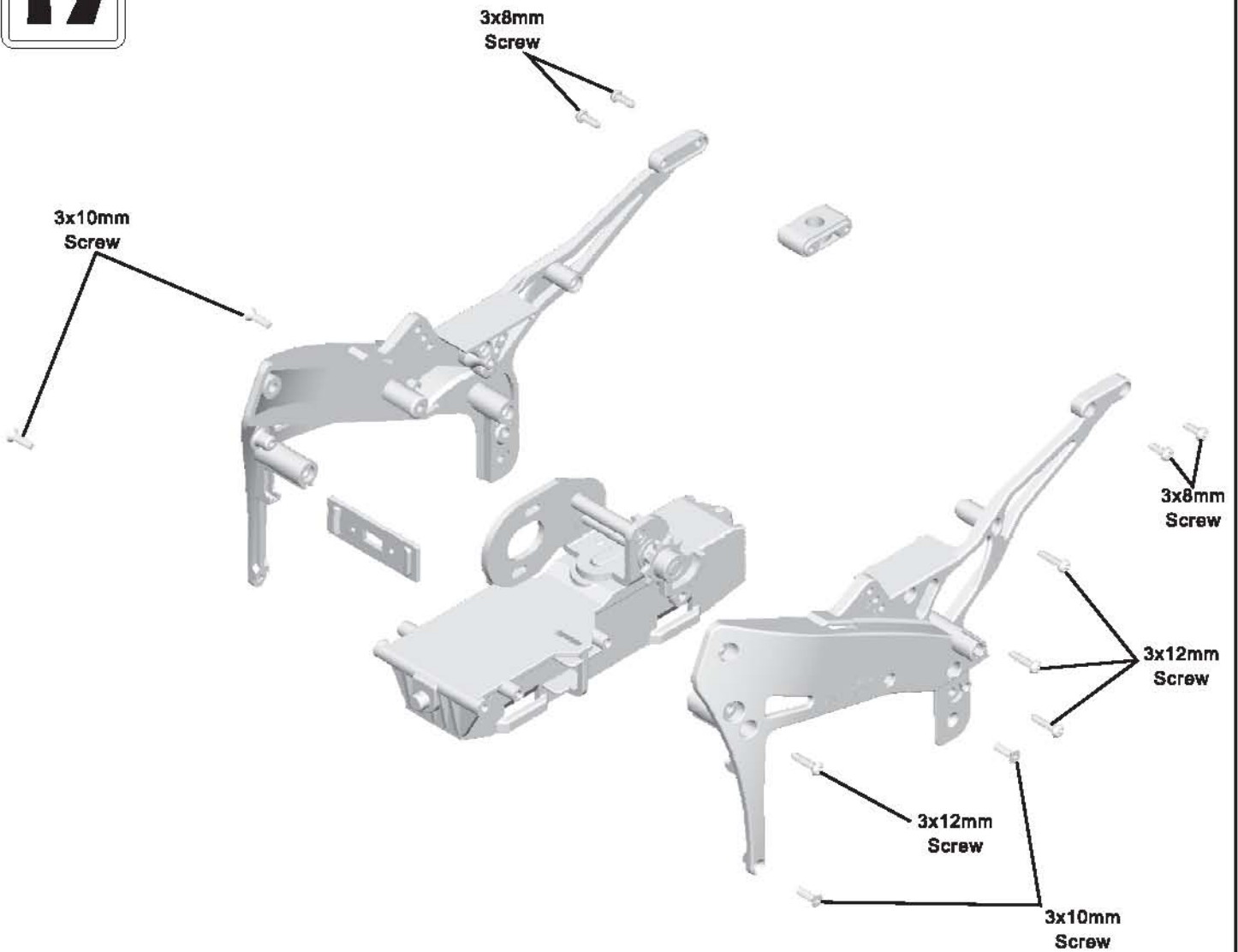

18



19



20



21

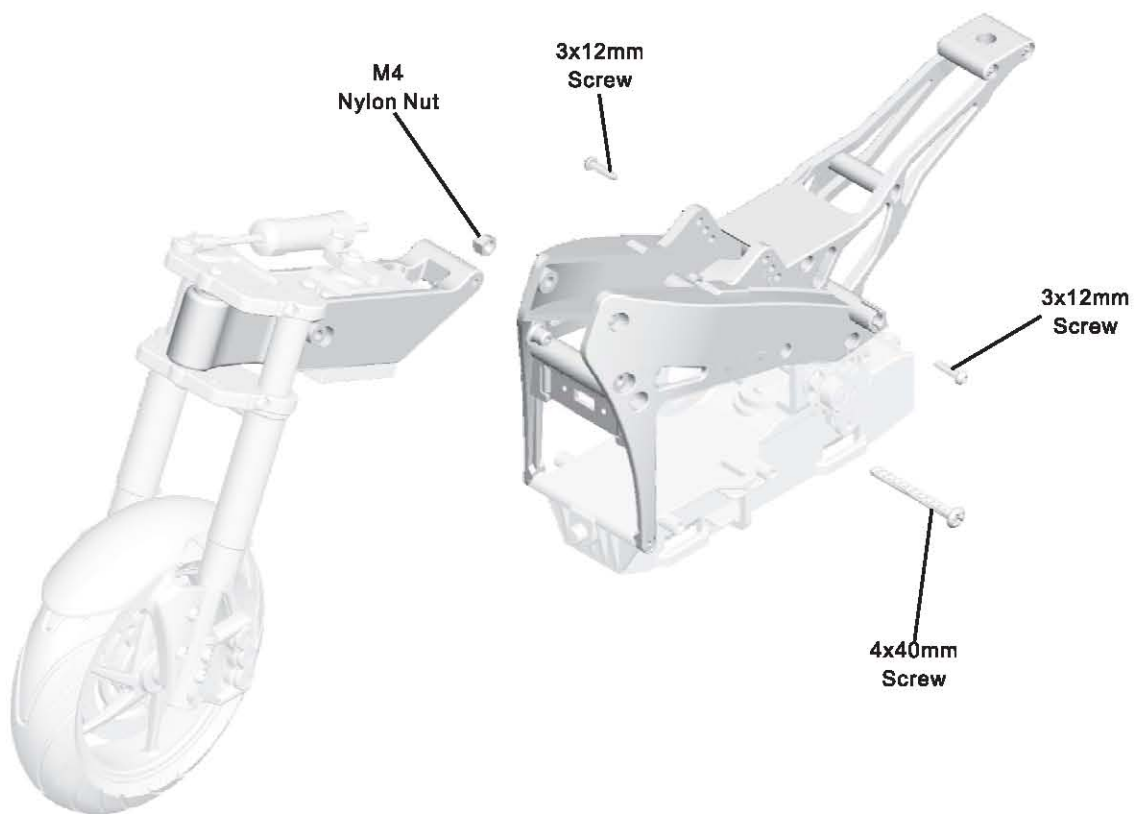

22



23

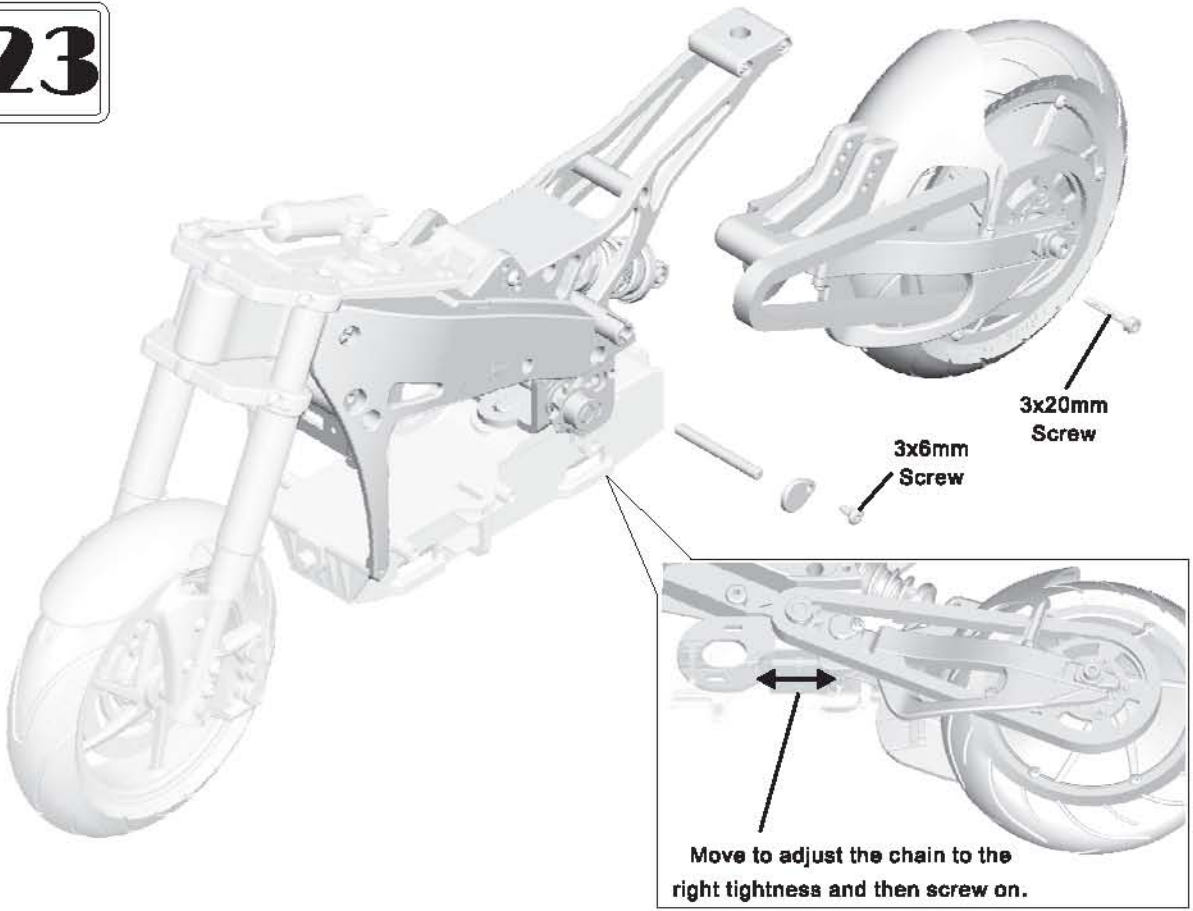

24



25

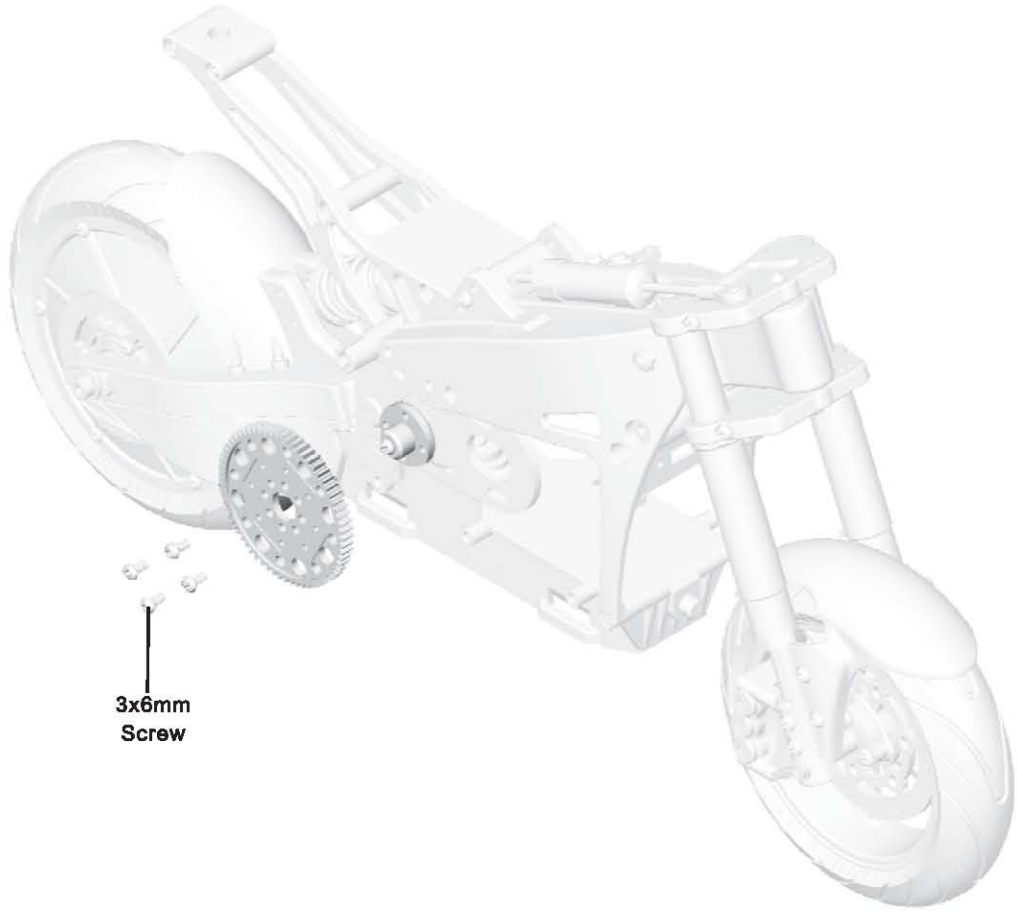

3x6mm
Screw

26



3x8mm
Screw

3x10mm
Screw

27

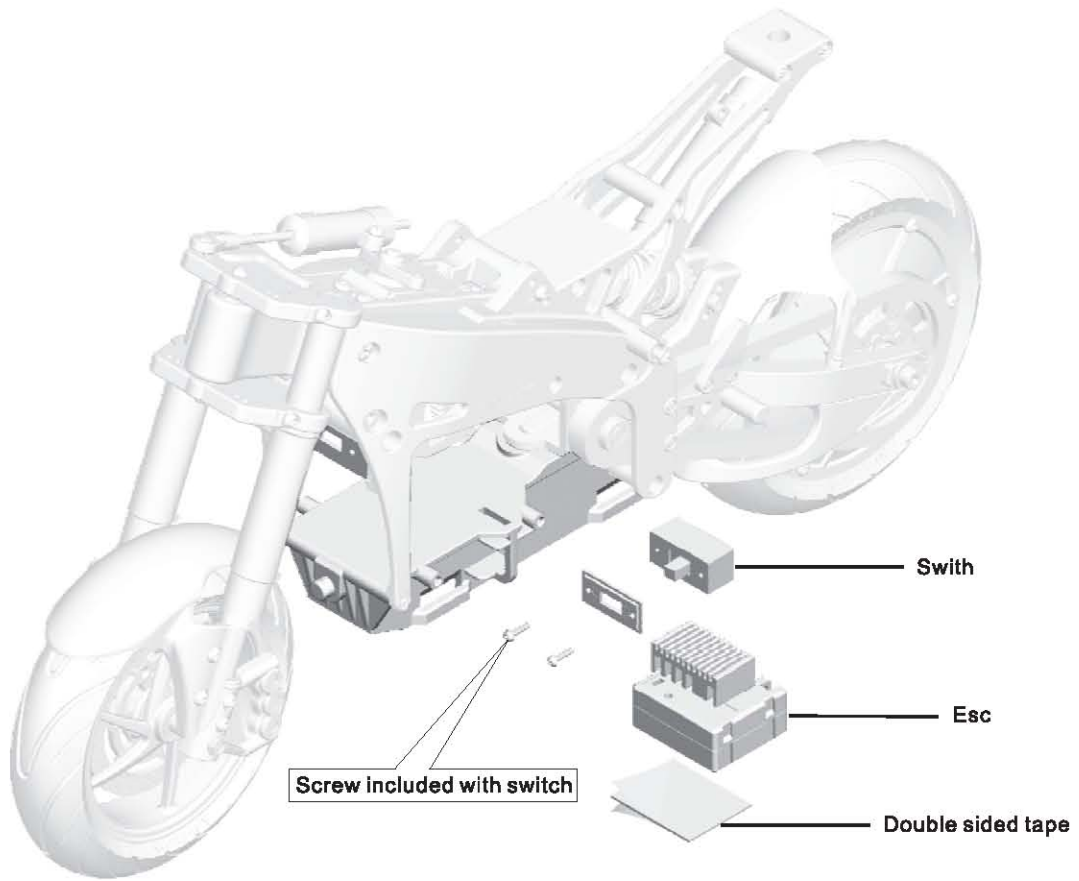

28

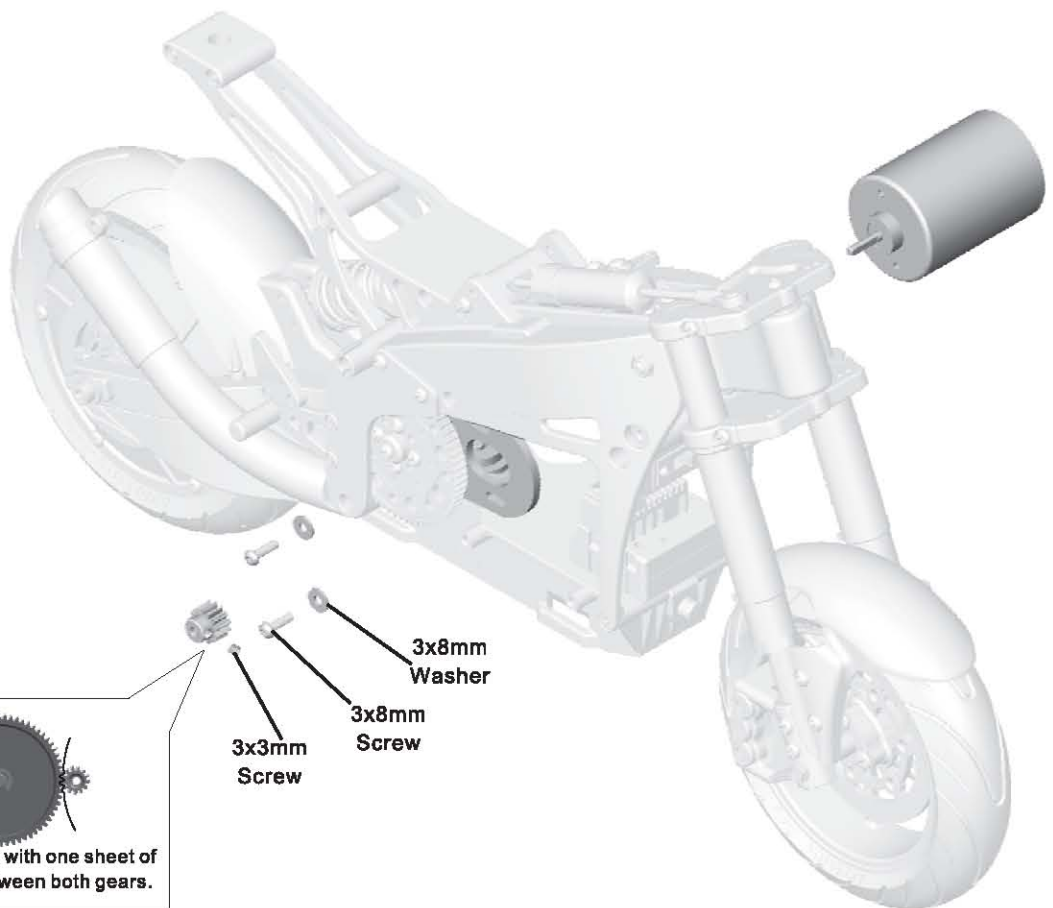

29

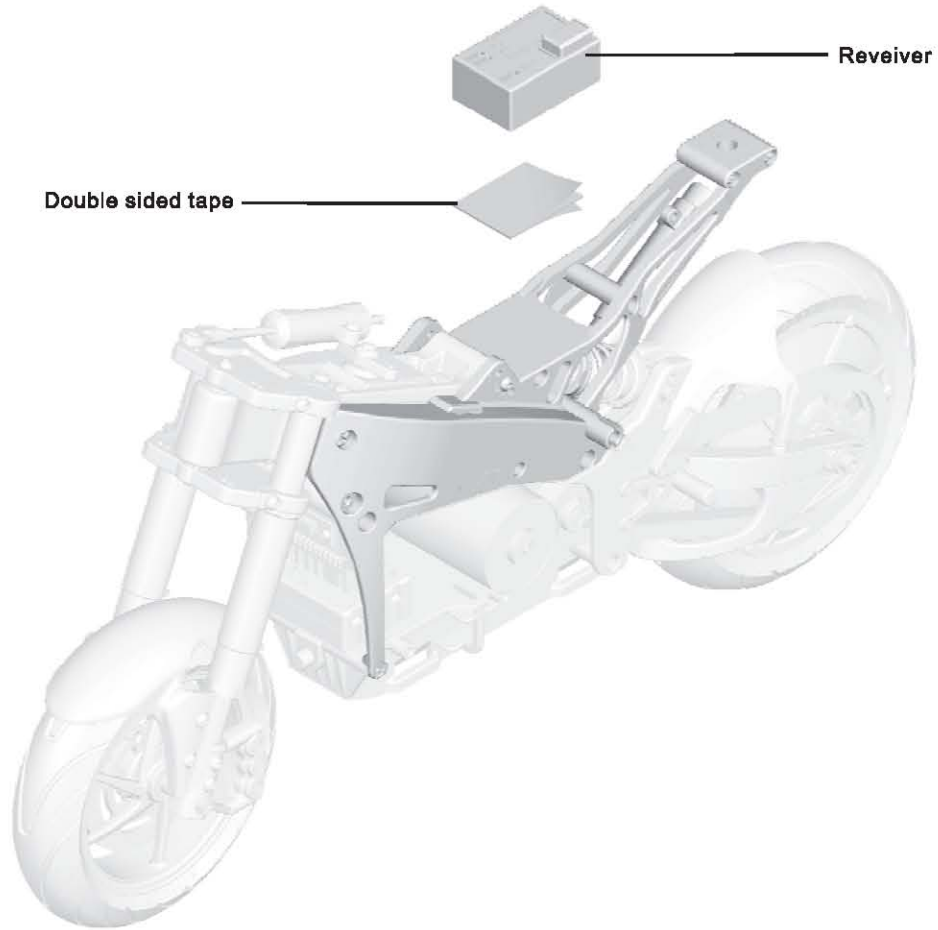

30



31

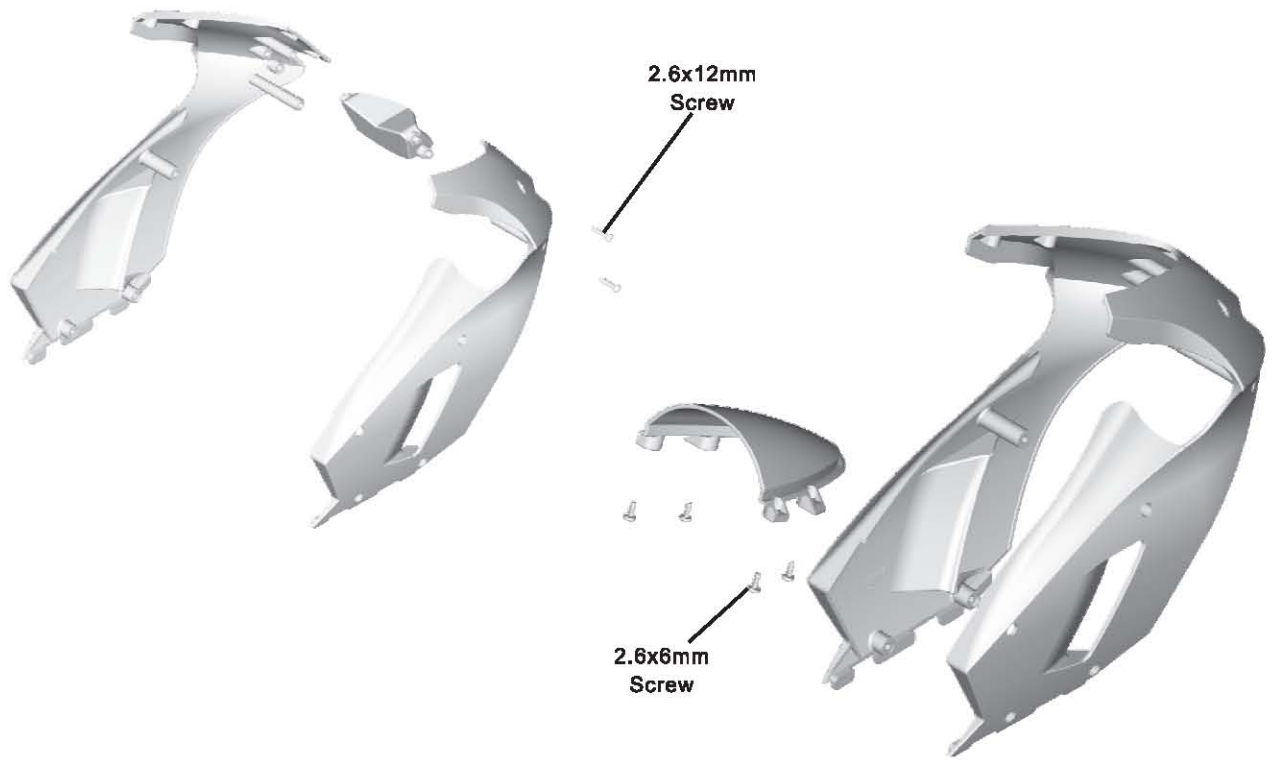

32

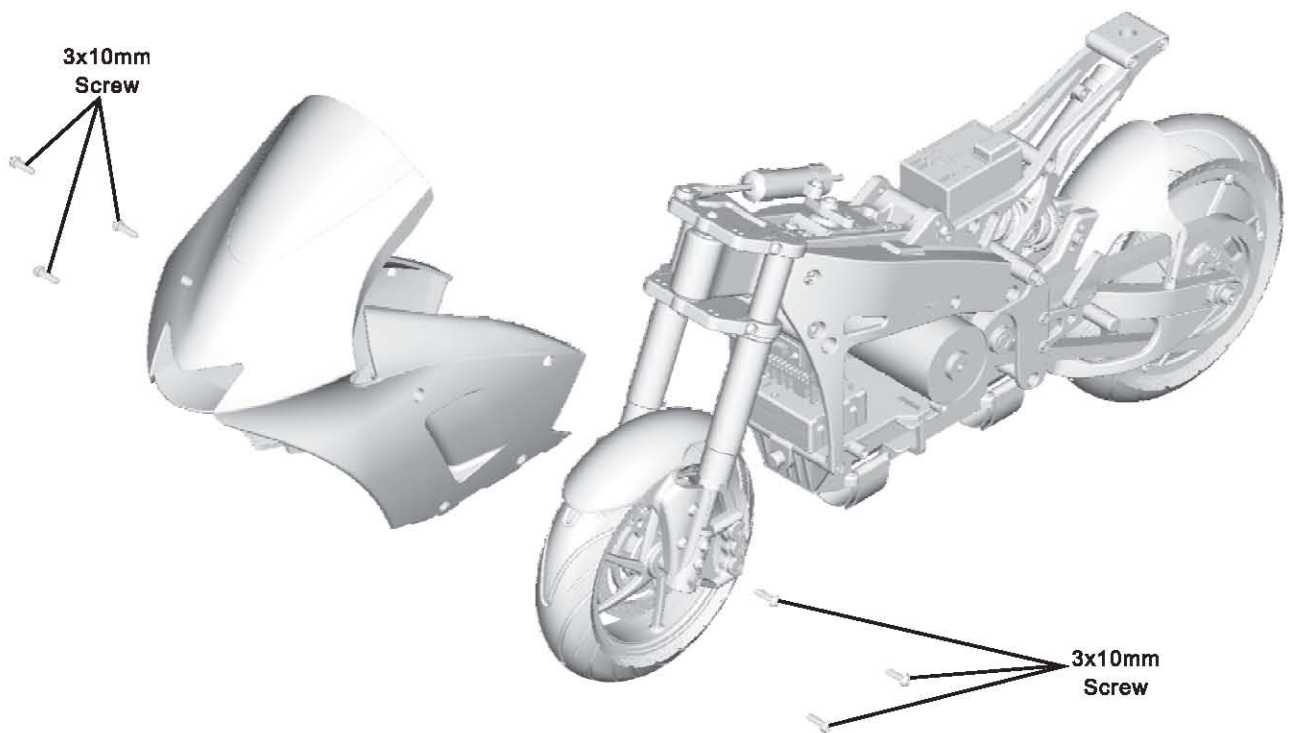

33



34

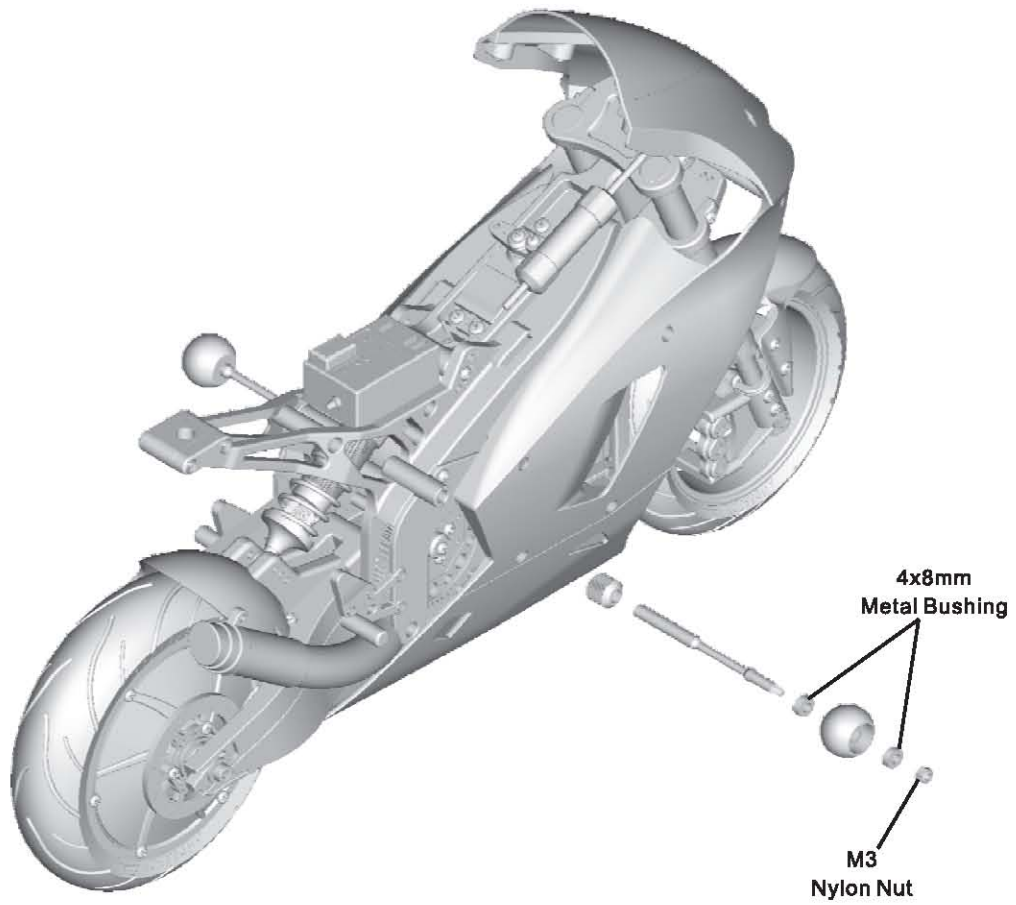

35

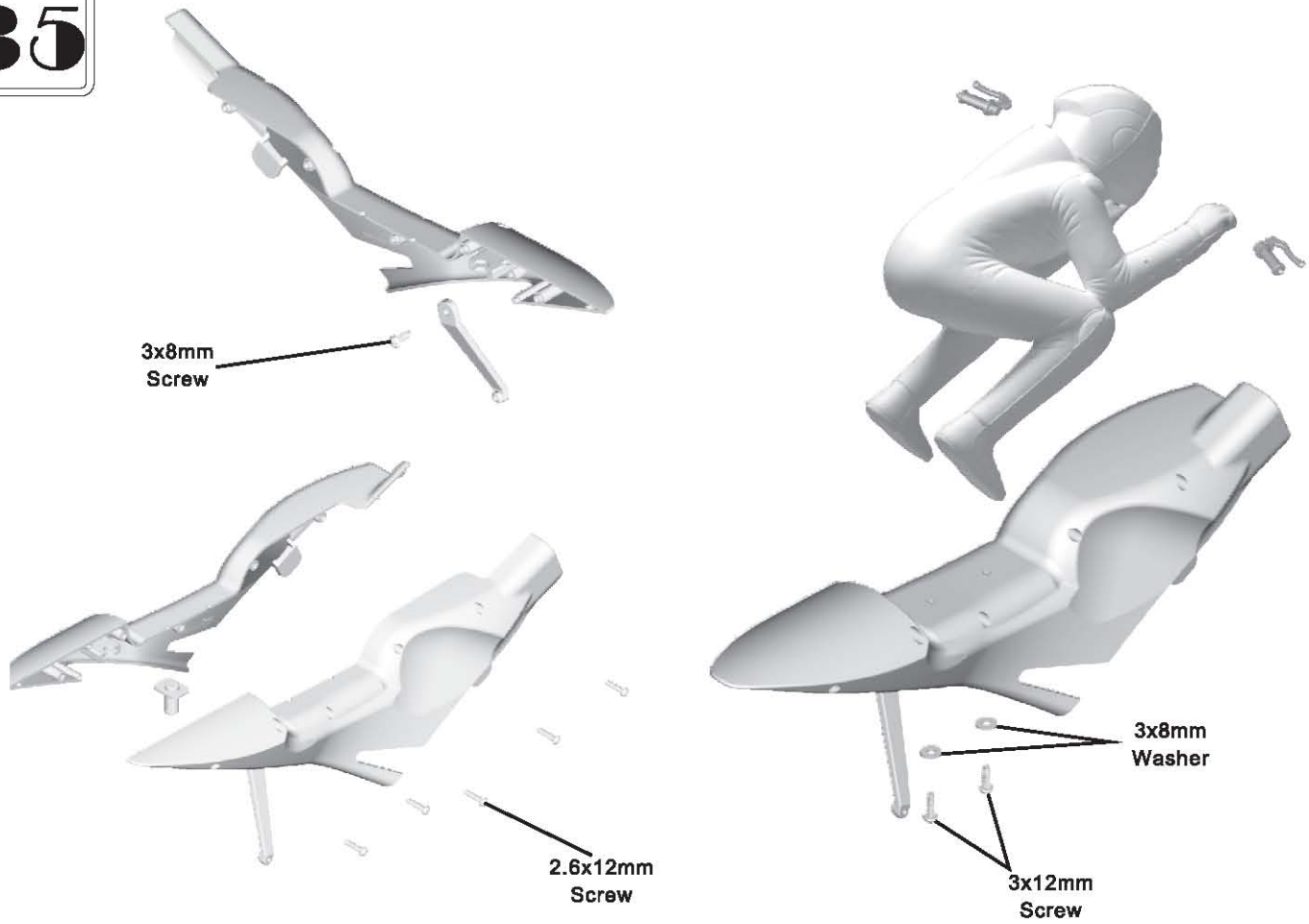

36

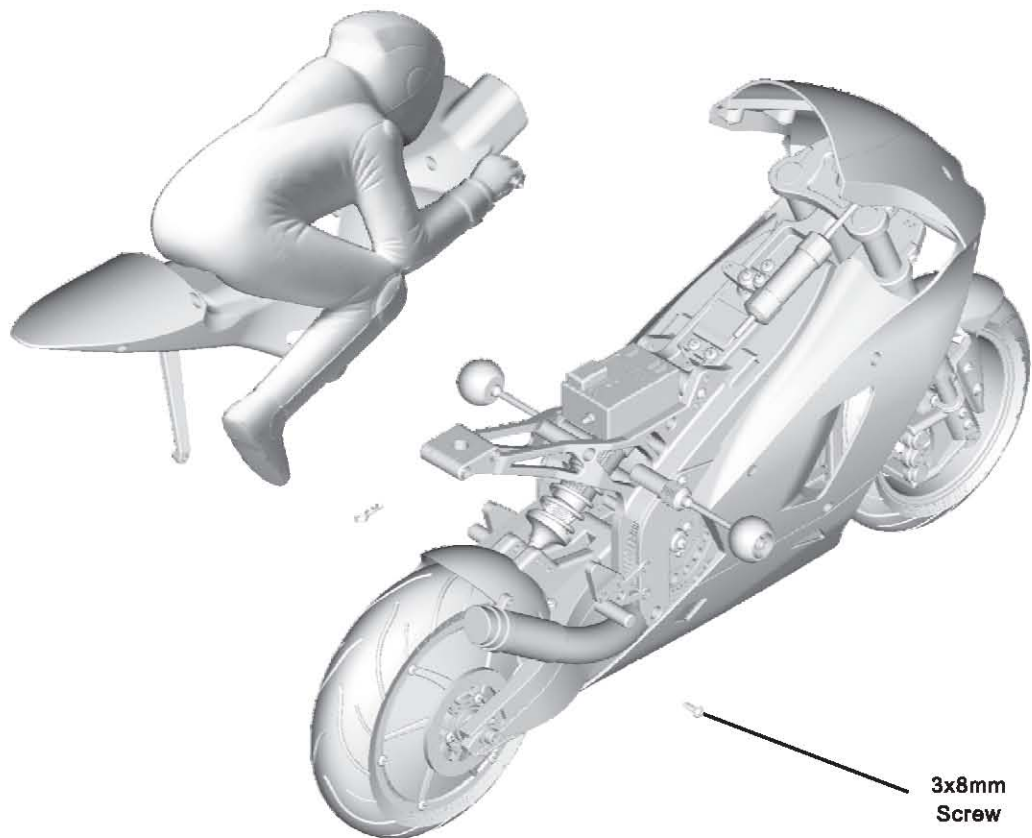

Setting

This is a design with CG steering system (counter steering system),
The direction between steering and front wheel is opposited.

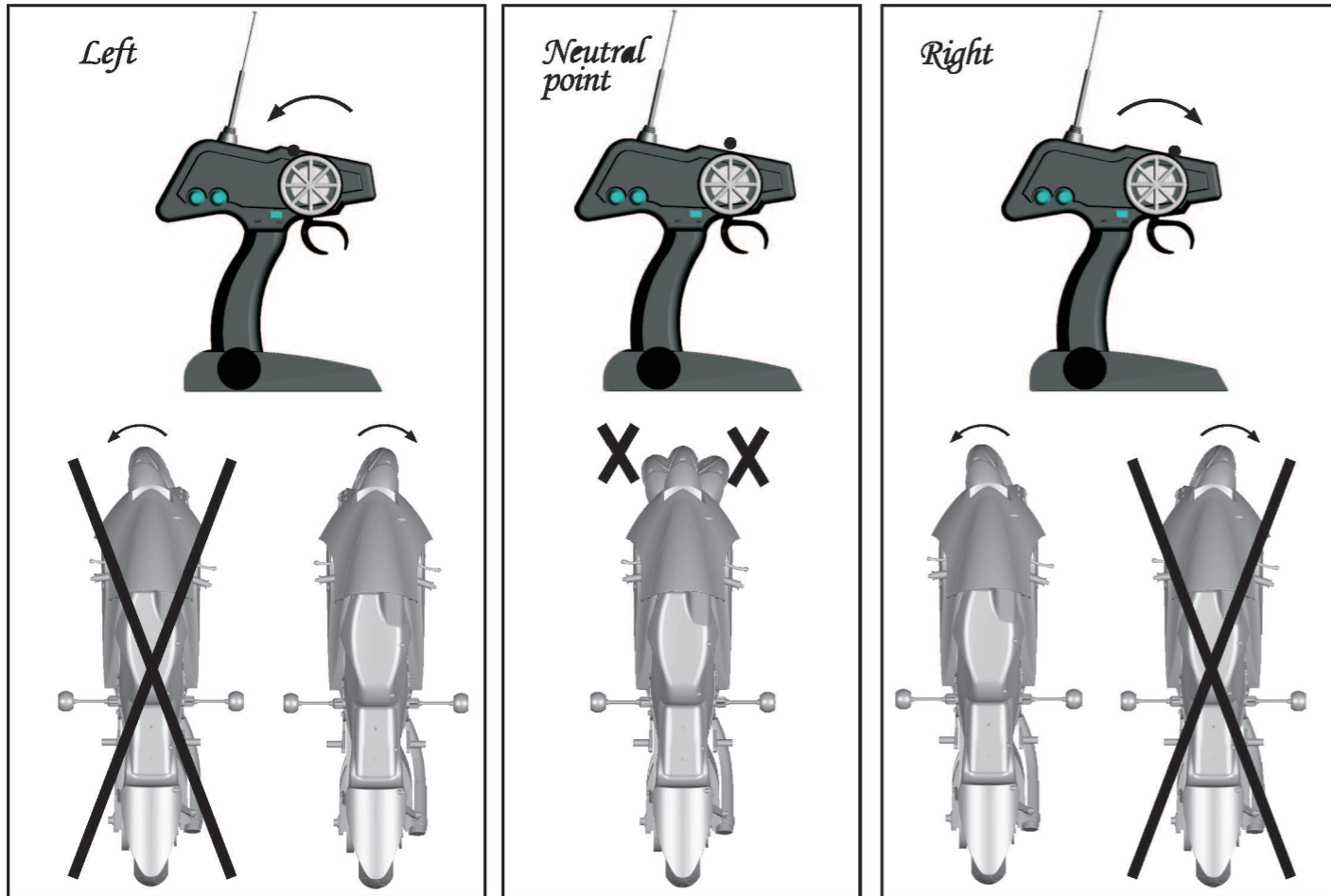

Operation

Smooth open parking lots or your local track will usually be the best choices .
Need 30-60 min for practicing.

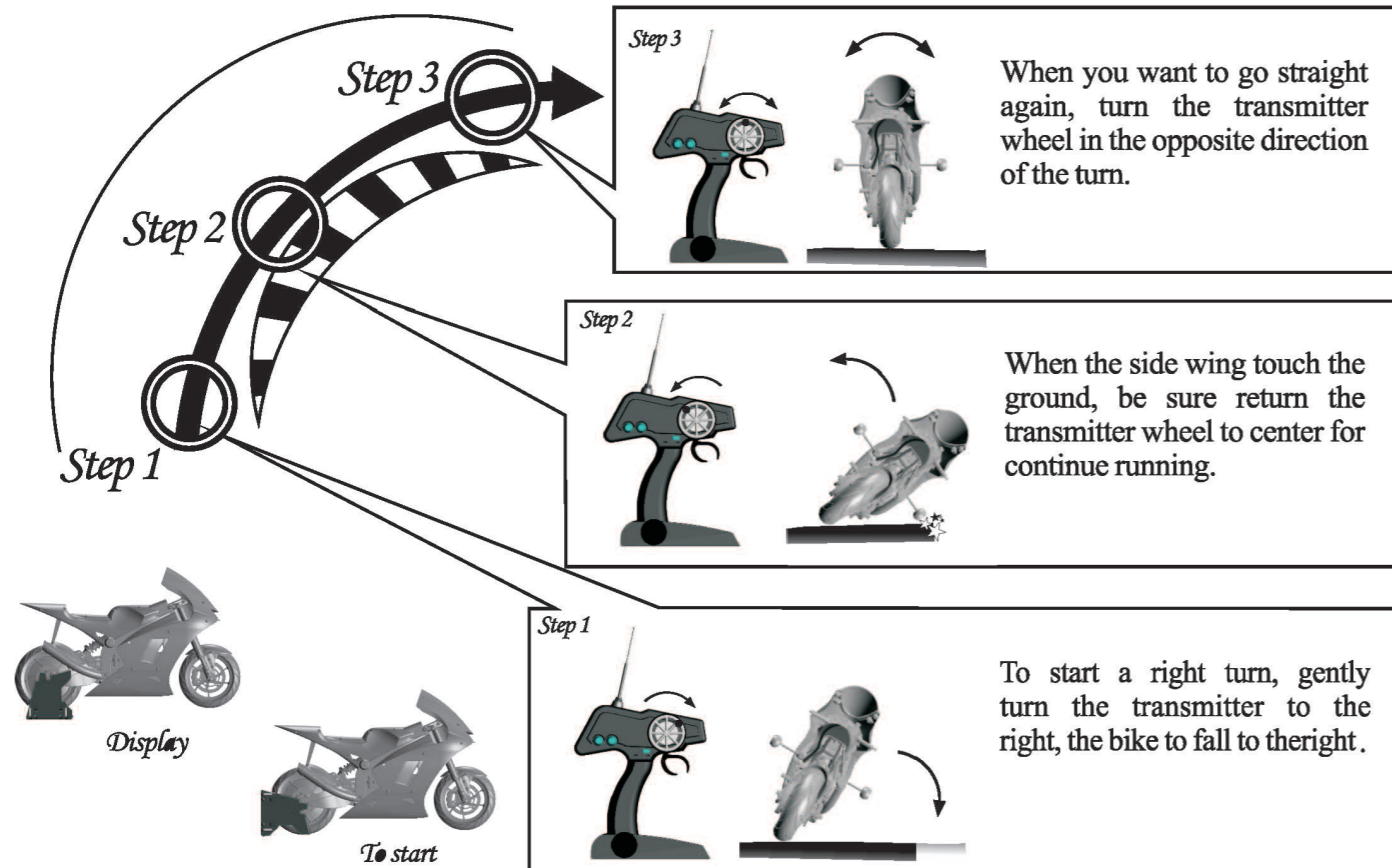

Cap Head



Flat Head



Pin



O Ring



Notes

Button Head

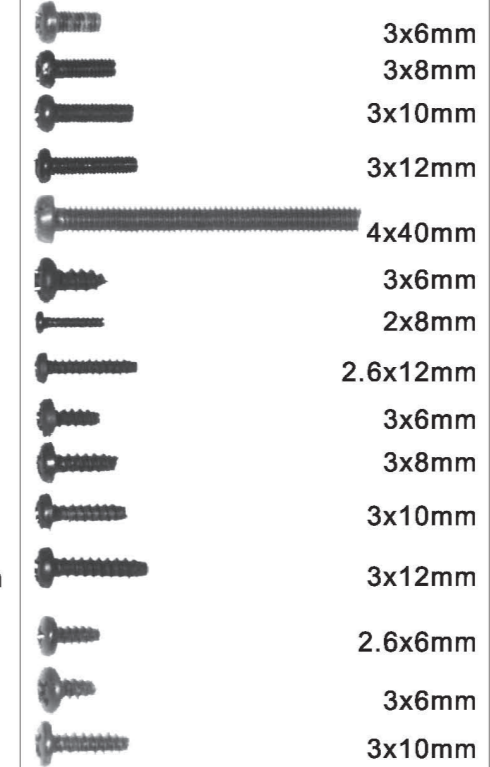

Setscrews



Nuts



E Clip



45° R Clip





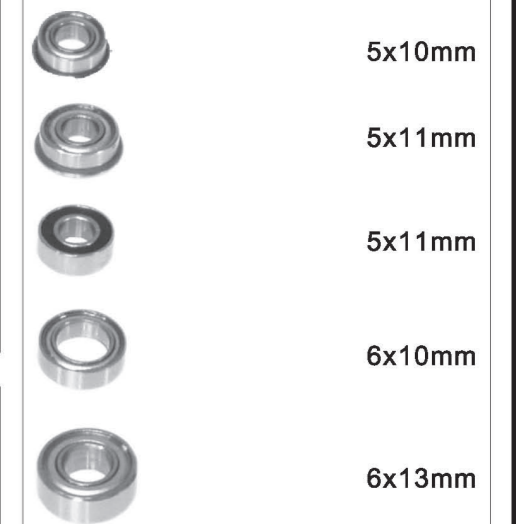



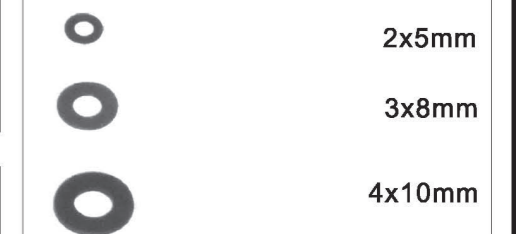

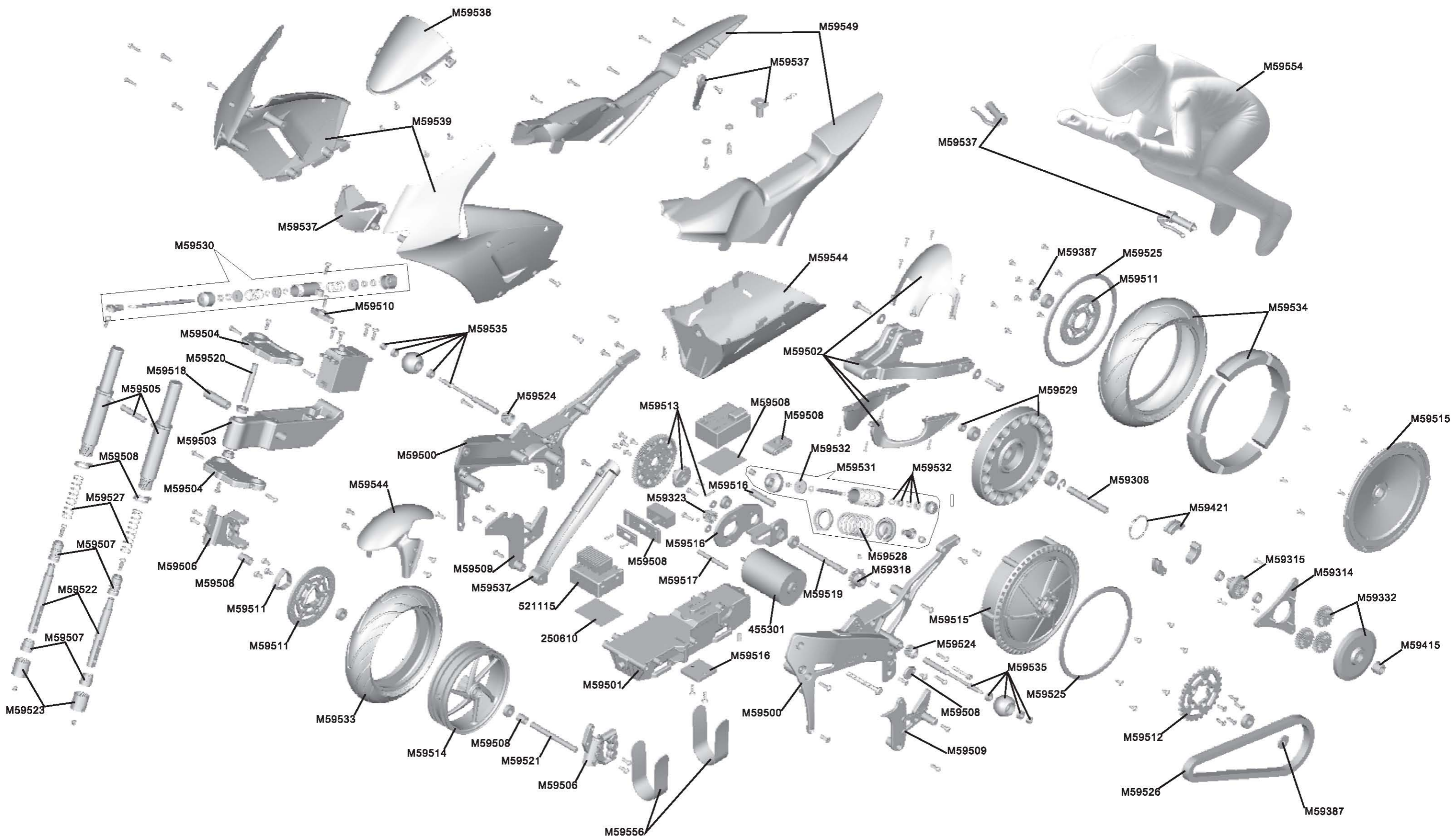













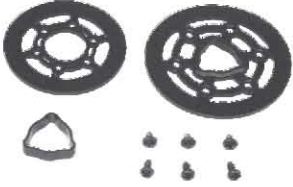

Ball Bearings











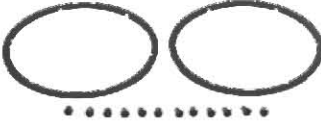
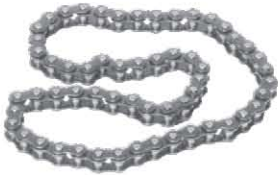















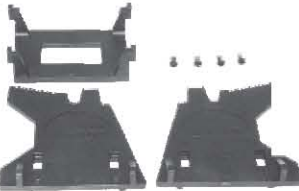



















Shims & Washers





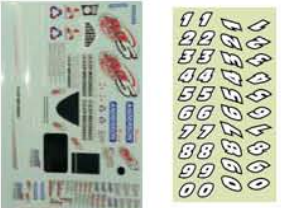

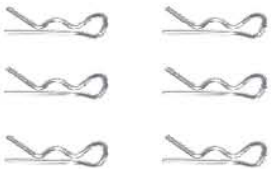
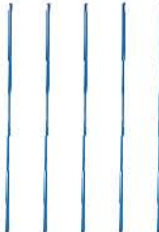

















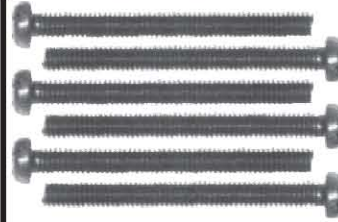

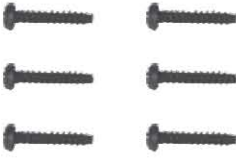

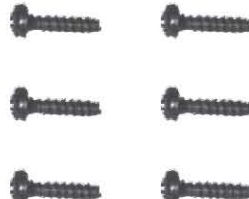
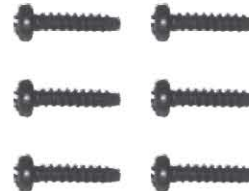
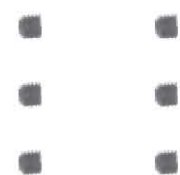







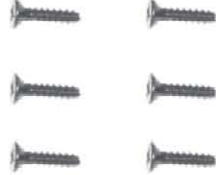



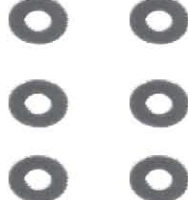
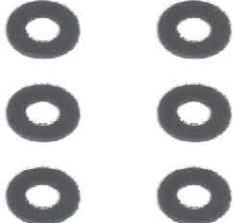

M59500	M59501	M59502	M59503	M59504	M59505
 <p>Main Frame</p>	 <p>Battery Case</p>	 <p>Rear Arm Set</p>	 <p>Front Suspension Mount</p>	 <p>Front Shock Mount</p>	 <p>Front Shock Body</p>
M59506	M59507	M59508	M59509	M59510	M59511
 <p>Front Hub Carrier</p>	 <p>Front Shock Piston Set</p>	 <p>Chassis Accessories</p>	 <p>Pedal</p>	 <p>Servo Arm</p>	 <p>Brake Disc</p>
M59512	M59513	M59514	M59515	M59516	M59517
 <p>Sprocket Plate</p>	 <p>65T Main Gear</p>	 <p>Front Wheel</p>	 <p>Rear Wheel</p>	 <p>Motor Mount</p>	 <p>Rear Arm Shaft</p>
M59518	M59519	M59520	M59521	M59522	M59523
 <p>Front Suspension Shaft</p>	 <p>Main Shaft</p>	 <p>King Shaft</p>	 <p>Front Wheel Axle</p>	 <p>Front shock Shaft</p>	 <p>Front Shock Lower Cap</p>

M59524	M59525	M59526	M59527	M59528	M59529
 <p>Stabilizer Bar End</p>	 <p>Rear Tire Holder Plate</p>	 <p>Chain</p>	 <p>Front Shock Spring</p>	 <p>Rear Shock Spring</p>	 <p>Flywheel Gyro</p>
M59530	M59531	M59532	M59533	M59534	M59535
 <p>Oil Steering Dampers Rod Set</p>	 <p>Oil Rear Shock Set</p>	 <p>Shock service Kit</p>	 <p>Front Tire</p>	 <p>Rear Tire</p>	 <p>Stabilizer Bar</p>
M59536	M59308	M59314	M59315	M59318	M59323
 <p>Ball Bearing Set</p> <p>5x10F 2pcs 5x11F 2pcs 5x11 2pcs 6x10 2pcs 6x13 4pcs</p>	 <p>Rear Wheel Axle</p>	 <p>Planetary Gear Mount</p>	 <p>Clutch Shoes Mount</p>	 <p>9T Sprocket</p>	 <p>13T Pinon</p>
M59332	M59368	M59387	M59415	M59421	M59537
 <p>Planetary Gear Set</p>	 <p>Bike Stand</p>	 <p>Washer For Rear Wheel Axle</p>	 <p>One Way Bearing</p>	 <p>Metal Clutch Shoe</p>	 <p>Body Accessories</p>

M59538  Windshield	M59539  Body-Front (White)	M59540  Body-Front (Blue)	M59541  Body-Front (Red)	M59542  Body-Front (Green)	M59543  Body-Front (Yellow)
M59544  Body-Bottom (White)	M59545  Body-Bottom (Blue)	M59546  Body-Bottom (Red)	M59547  Body-Bottom (Green)	M59548  Body-Bottom (Yellow)	M59549  Body-Upper (White)
M59550  Body-Upper (Blue)	M59551  Body-Upper (Red)	M59552  Body-Upper (Green)	M59553  Body-Upper (Yellow)	M59554  Printing ready Driver (Red)	M59555  Printing Ready Driver (Blue)
M59556  Battery Strap	M59557  Body & Number Decals	M59371  Number Decals	252548  45° R-Clips	258038  Color Antenna (Blue)	258039  Antenna Cover

521405	455301	521175 PRO	455201 PRO	M59369	421420
 15T Speed Control	 540 Motor 28000rpm	 Brushless Speed Control 75A For Motobike	 Brushless Motor 500	 Brush	 Hex Straight Allen 1.5mm 2.0mm 2.5mm 3.0mm
421430	421431	421508	421506	615008	258276
 Phillips Wrench (0)	 Phillips Wrench (1)	 Nut Driver 7mm	 Nut Driver 5.5mm	 Connector	 3x6mm Screw
258837	254049	258935	252541	252528	254019
 3x8mm Screw	 3x10mm Screw	 3x12mm Screw	 4x40mm Screw	 3x6mm Screw	 2x8mm Screw
258148	252529	252530	254024	252542	254029
 2.6x12mm Screw	 3x6mm Screw	 3x8mm Screw	 3x10mm Screw	 3x12mm Screw	 3x3mm Setscrew

254030	252543	258648	258638	254054	258151
 <p>4x4mm Set Screw</p>	 <p>4x8mm Set Screw</p>	 <p>3x6mm Screw</p>	 <p>3x8mm Screw</p>	 <p>3x10mm Screw</p>	 <p>2.6x10mm Screw</p>
254036	254037	252544	254076	254006	258055
 <p>M3 Nut</p>	 <p>M4 Nut</p>	 <p>2.5x6mm Washer</p>	 <p>3x8mm Washer</p>	 <p>4x10mm Washer</p>	 <p>2x5mm Screw</p>
252545	258271	254021	252546	254023	258835
 <p>3x20mm Screw</p>	 <p>4x16mm Screw</p>	 <p>2.6x6mm Screw</p>	 <p>3x6mm Screw</p>	 <p>3x10mm Screw</p>	 <p>2mm E Clip</p>
258142	252547	254027			
 <p>5mm E Clip</p>	 <p>3x10mm Screw</p>	 <p>(For Steering Rod) P3 O Ring</p>			



ANDERSON MODEL COMPANY., LTD

<http://www.andersonmodel.com>